

Exploring the multi-robber damage number of a graph

Simona Gagarova*

Project advisor: Japheth Varlack†

Abstract

We consider a variant of the Cops and Robbers game on graphs where robbers damage visited vertices. In this version, multiple robbers aim to maximize vertex damage, while a single cop seeks to minimize it. For s robbers against one cop, we completely characterize the graphs on $n \geq 2s + 2$ vertices with the smallest possible damage number when $s > 2$. Furthermore, we determine the s -robber damage number for various families of graphs. We also examine conditions under which the cop can save k vertices from damage against s robbers for $k > 3$. For triangle-free graphs, we establish that the cop can achieve this objective provided the graph's maximum degree is at least $\binom{s}{2} + k - 1$. We further present upper and lower bounds on the minimum maximum degree for non-triangle-free graphs, under which the cop can ensure k vertices are saved for $k \leq 2\binom{s}{2}$.

1 Introduction

Cops and Robbers is a perfect-information pursuit-evasion game played on simple graphs, first introduced in [9, 11]. The original version of the game features two opposing players: a cop and a robber. The cop's objective is to capture the robber, while the robber aims to evade capture for as long as possible. The game is initialized in round 0, with the cop selecting a vertex, followed by the robber selecting a different vertex as their starting position. This choice is a part of each player's strategy. Subsequently, each round proceeds as follows: the cop moves from the vertex currently occupied to one of its neighbours or passes, then the robber has the same choice. The cop wins the game if the two players occupy the same vertex (the robber is *caught*).

Graphs for which the cop has a strategy to capture the robber in a finite number of rounds are called *cop-win* graphs by [9]. One such example is the path P_n , for $n \geq 2$. Alternatively, if the robber has a strategy to evade capture indefinitely, the graph is called *robber-win*. Later, the game was extended to include opposing teams of multiple cops and robbers, where all players on a given team move simultaneously. If k cops are sufficient to capture one robber, the graph is called a k -cop-win graph (introduced in [13]). For a

*Sofia High School of Mathematics, Bulgaria (simona.gagarova@abv.bg)

†(japhethv1229@gmail.com)

k -cop-win graph, determining the number of moves required for the k cops to win is also a significant area of interest. This invariant is denoted by $\text{capt}_k(G)$ for $k > 1$ cops and $\text{capt}(G)$ for one cop in [1].

A variant of the Cops and Robbers game is introduced in [5], where a vertex becomes *damaged* if the robber occupies it in a given round and is not captured in the next round. In essence, the robber damages the vertices he visits. Those vertices stay part of the game and can be used in subsequent rounds. This variation of the game leads to the introduction of the following graph parameter.

Definition 1.1. The damage number of a graph G , denoted $\text{dmg}(G)$, is the minimum number of vertices damaged over all games played on G where the robber plays optimally.

In this version of the game, the roles of the cop and the robber are altered: the cop now seeks to minimize the damage, and the robber wants to maximize it. By the definition of capture time, it is evident that for cop-win graphs $\text{dmg}(G) \leq \text{capt}(G) - 1$ as shown by Cox and Sanei in [5]. Graphs achieving equality exist; for example, if G is a graph with a universal vertex or a tree, then $\text{dmg}(G) = \text{capt}(G) - 1$. However, Cox and Sanei show graphs where the damage number is less than half of the capture time, indicating the cop's primary focus is to limit the robber's access to as many vertices as possible.

For robber-win graphs, the robber's role becomes more intrusive. Rather than simply avoiding capture indefinitely, he aims to traverse the graph as much as possible. For instance, in C_n , $n > 3$, the robber can damage half of the vertices without being captured, proven in [5]. This change in the gameplay makes examining games with multiple robbers particularly interesting. (This differs from the common setting where multiple cops play against one robber since a strategy to capture one robber repeated multiple times is sufficient to capture all players in the robbers' team). This motivates the authors in [5] to introduce the multi-robber damage number.

Definition 1.2. Suppose G is a simple graph. The s -robber damage number of G denoted $\text{dmg}(G; s)$, is the minimum number of vertices damaged in G over all games played on G where s robbers play optimally against one cop. Note that optimal play for the robbers is still to damage as many vertices as possible.

In [4], the authors establish general bounds on the damage number, including that the cop can always save 2 vertices simply by patrolling the endpoints of an edge. They determine the exact value of $\text{dmg}(G; s)$ for several graph families, including cycles, paths, stars, and spider graphs. Furthermore, they characterize the graphs with extreme values of $\text{dmg}(G; 2)$, showing that the threshold graphs are the only graphs with $\text{dmg}(G; 2) = 1$, the smallest possible damage number for 2 robbers. This leads to the question of whether the threshold graphs are exactly the graphs for which $\text{dmg}(G; s) = s - 1$. We investigate this question further in Section 2.

As the authors in [4] observe that the cop can always save 2 vertices, they raise the question: When can the cop save three vertices? They study this question for the

case $s = 2$ robbers and show that the cop can always achieve this goal in any graph G with $\Delta(G) \geq 3$, where $\Delta(G)$ is the maximum degree of the graph G . This leads to the conjecture that for any graph G with $\Delta(G) \geq \binom{s}{2} + 2$, the cop can always save three vertices. This conjecture is the central focus of [12], where the authors prove that it holds for triangle-free graphs. For non-triangle-free graphs, they provide counterexamples that disprove the conjecture. Furthermore, they establish upper and lower bounds on the minimal $\Delta(G)$ required for the cop to save three vertices in the graph G .

Here, we focus on the s -robber damage number. The graphs we consider are finite, undirected, and simple. We use the graph-theoretic notation as presented in [14] and terminology of Cops and Robbers from [2]. For clarity, we will refer to the cop as "she" and the robber as "he". In Section 2, we characterize the graphs that achieve the minimal possible value of $dmg(G; s) = s - 1$ for $s \geq 3$, showing that these graphs are a subset of the family of threshold graphs. In Section 3, we generalize the approach in [12] and establish bounds on the minimal $\Delta(G)$ necessary for the cop to save k vertices, using the graphs $K_{1,m}$ and $\Theta(lP_7)$. We consider separately the family of triangle-free graphs and the family of non-triangle-free graphs. For the second family, we analyze only the case for $k \leq 2\binom{s}{2}$. In Section 4, we determine $dmg(G; s)$ for various graph families, including fan and wheel graphs, gear and accordion graphs, and complete bipartite graphs. For a graph H_n , described in Section 4, we show that $dmg(H_n; s) = n - 2$ for $s \geq 5$. This raises the question: What is the minimal number of robbers, $s_{min}(G)$, required to devise a strategy that damages all but two vertices? We conclude by proposing future research directions.

2 Graphs with minimal s -robber damage number

We begin by examining the s -robber damage number and focusing on graphs for which this number is minimized. For any graph G with at least $s + 1$ vertices, we observe that its s -robber damage number is at least $s - 1$. This is because each robber can damage their initial vertex, and the cop can capture at most one robber in the first round.

This question is inspired by the result in [4]. The authors show that the only graphs on five or more vertices that achieve $dmg(G; 2) = 1$ are the threshold graphs. In this section, we consider only graphs with more than $s + 3$ vertices. We demonstrate that a graph G of this order has $dmg(G; s) = s - 1$ if and only if it is a specific type of threshold graph.

Before we turn our attention to the characterization of these graphs, let us introduce some notation first.

Definition 2.1 ([7]). A graph G is a *threshold graph* if it can be constructed from a single vertex by repeated additions of a single isolated vertex or a single universal vertex.

Alternatively, the threshold graphs can be characterized by their forbidden subgraphs: a graph is a threshold graph **iff** no four of its vertices contain P_4 , C_4 or $K_2 \cup K_2$ as an induced subgraph.

Both of these definitions are essential for the arguments that follow. Since the structure of a threshold graph is central to our discussion, we provide further specifications on this topic. Let the largest connected component of a threshold graph G be called T_m , where m is the number of universal vertices added during the construction process. Let those vertices be called *big vertices* and label them as b_1, b_2, \dots, b_m respectively. Let the vertices $V(T_m) \setminus \{b_1, \dots, b_m\}$ be called small vertices. These are the vertices added as single isolated vertices during the composition of the graph, which are part of the largest connected component. Additionally, let S_0 be the set of small vertices connected to b_1, b_2, \dots, b_m , let S_1 be the small vertices connected to b_2, \dots, b_m , etc. This notation arises naturally, since in the construction process of G first are added the vertices S_0 , then is added b_1 , followed by the addition of the vertices S_1 , and the big vertex b_2 , etc. until the last universal vertex b_m is added and the last isolated vertices (the rK_1). Refer to Figure 1a for this distribution, where we have grouped the vertices into layers ($S_i \cup b_i$ are in layer L_i , for $1 \leq i \leq m-1$, S_0 are in layer L_0 , and b_m is in layer L_m). We say that $G = T_m \cup rK_1$ whenever G is a threshold graph.

We say that a vertex v in layer L_i is higher than vertex u in layer L_j whenever $i > j$. This structure has the property that b_i is adjacent to all vertices in layers L_0, L_1, \dots, L_{i-1} . Furthermore, all vertices within a single layer induce an independent set. Also, a small vertex in L_i is connected only to the big vertices $b_j, j > i$.

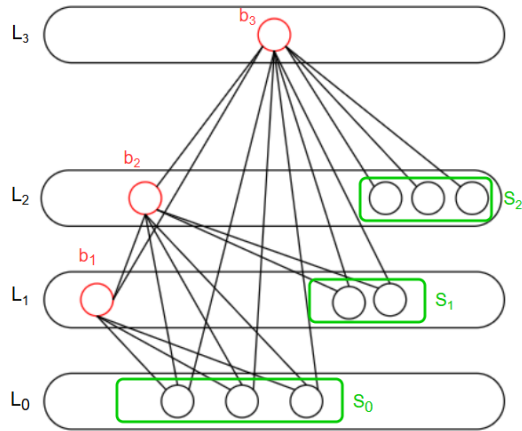

(a) Labeling of the threshold graph $G = T_3$.

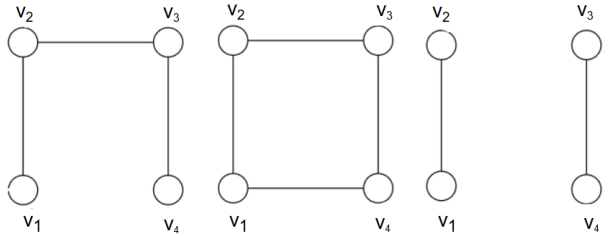

(b) Forbidden induced subgraphs of a threshold graph: P_4, C_4 and $P_2 \cup P_2$.

Figure 1: Visualization of both definitions of a threshold graph.

We now proceed to prove some helpful statements that establish certain restrictions on the graphs G , which minimize the damage number for $s \geq 3$ robbers.

Lemma 2.2. *Let G be a graph on $n \geq s + 3$ vertices. If G is not a threshold graph, then $\text{dmg}(G; s) \geq s$.*

Proof. Suppose a cop and robbers R_1, R_2, \dots, R_s play on a graph G which is not a thresh-

old graph. Then, by definition, G contains one of P_4 , C_4 , and $P_2 \cup P_2$ as an induced subgraph, and let us call this specific subgraph A . Consider the labeling, shown in Figure 1b.

If the cop does not capture any robbers in the first round, then each of the robbers damages their initial vertex, which leads to s damaged vertices. Suppose that she captures a robber in the first round.

Now, if the cop is initially placed on v_1 , then place R_1 and R_2 on v_2 and v_3 accordingly, and place R_3, \dots, R_s on $s - 2$ unoccupied vertices of $G \setminus A$. In the first round, R_1 aims to move to v_1 , R_2 aims to move to v_4 , and the other robbers stay in their places. If the cop moves to v_2 and captures R_1 , then R_2 will damage both v_3 and v_4 as $v_2v_4 \notin E(G)$. The cop cannot capture R_2 in the first round. If the cop captures R_i , where $3 \leq i \leq s$, in the first round, then the cop can capture at most one of R_1 and R_2 in the next round. Consequently, the other one will damage one of v_1 and v_4 . In both cases, s vertices are damaged, demonstrating that $dmg(G; s) \geq s$. Analogously, we can deduce the same conclusion if the cop starts on v_4 .

If the cop is initially placed on a vertex v different from v_1 and v_4 , then place R_1 and R_2 on v_1 and v_4 accordingly and place R_3, \dots, R_s on $s - 2$ unoccupied vertices outside of A . The strategy of R_1 and R_2 is to move to v_2 and v_3 . Because $v_1v_3, v_2v_4 \notin E(G)$, if the cop first captures one of R_1 and R_2 , the other one will damage one of v_2 and v_3 . If the cop first captures R_i , where $3 \leq i \leq s$, then R_1 and R_2 will successfully move to v_2 and v_3 . In the next round, the cop can capture at most one of them, so one of v_2 and v_3 will be damaged in round two. Therefore, after looking at all possible initial placements of the cop, the robbers can always damage at least s vertices in G , demonstrating that $dmg(G; s) \geq s$. \square

As we now know that if $dmg(G; s) = s - 1$, the G must be part of the family of threshold graphs, we are ready to proceed to the following theorem.

Theorem 2.3. *Let G be a graph on $n \geq 2s + 2$ vertices. Then, $dmg(G; s) = s - 1$ if and only if G is a threshold graph of one of the following forms:*

- $G = T_1 \cup rK_1, r \leq s - 1,$
- $G = T_2 \cup rK_1, r \leq s - 1, |S_0| = 1.$

Proof. (\implies) Suppose, by way of contradiction, that there exists a graph G with $n \geq 2s + 2$ vertices, $dmg(G; s) = s - 1$, and G is not one of the graphs described in the Theorem's statement.

Lemma 2.2 ensures that each graph, which is not a threshold graph, has s -robber damage number at least s . Therefore, by our assumption, G must be a threshold graph and $G = T_m \cup rK_1$, for some m and r .

Note that if $r \geq s$, then G has at least $s + 1$ connected components. Therefore, each robber can be placed in a single connected component, not containing the cop, and damage all of its vertices. This will result in at least s damaged vertices, which is a contradiction with the assumption.

Suppose that $r \leq s-1$. Let's observe that for the robbers' strategy, it is more optimal to place each robber in T_m rather than on an isolated vertex. If a robber is placed on a K_1 , all he can do is damage one vertex. If placed in T_m , he has the opportunity to damage at least 2 vertices in G , given that he is not the first captured robber. Therefore, we can suppose that all robbers start in T_m and only look at the game played on T_m .

The initial assumption forbids $m = 1$ and $m = 2$ with $|S_0|= 1$. Therefore, our $G = T_m \cup rK_1$, $r \leq s-1$, is with either $m \geq 3$ or $m = 2$ and $|S_0| \geq 2$. Note that if $m = 0$, then G is isomorphic to $\overline{K_n}$ and $dmg(\overline{K_n}; s) = s([4])$. Now, our goal is for each of these families of graphs to present a strategy for the robbers, which ensures the damage of at least s vertices.

Before we continue with the investigation of the cases, let us state two important observations. If the cop cannot capture any robber in the first round, all of them will damage their initial vertices. Additionally, if two robbers move to two undamaged vertices in the first round, then in the second round, the cop can capture at most one of them, and the remaining robber will damage the other vertex. Both scenarios ensure s damaged vertices. The robbers' strategy in the following cases is to force one of these two situations. From here, we divide the proof into two cases.

First case: Suppose that $G = T_m \cup rK_1$, $r \leq s-1$, and $m \geq 3$, at least $s-m+3$ small vertices and $dmg(G; s) = s-1$. Note that the first layer always contains at least one vertex ($|S_0| \geq 1$) and that the induced subgraph from the big vertices and one small vertex from the first layer is isomorphic to K_{m+1} . We now consider the possible initial placements of the cop and show that the robbers always have a strategy to damage at least s vertices to achieve a contradiction.

If the cop is initially placed on $u = b_i$, then the initial placement of the robbers will follow the placement strategy in Algorithm 1.

Algorithm 1

```

1: put  $R_1$  on  $b_1$ 
2:  $j \leftarrow 0$ 
3: while any robbers left &  $j \leq m-1$ 
   do
4:   occupy the small vertices  $S_j$ 
5:    $j \leftarrow j+1$ 
6: end while
7: if any robbers left then
8:   occupy the big vertices,
9:   starting from the lowest free
10: end if

```

Algorithm 2

```

1: put  $R_1$  on  $b_{i+1}$  and  $R_2$  on  $b_{i+2}$ 
2:  $j \leftarrow 1$ 
3: while any robbers left &  $j \leq m-1$ 
   do
4:   occupy the small vertices  $S_j$ 
5:    $j \leftarrow j+1$ 
6: end while
7: if any robbers left then
8:   occupy the big vertices,
9:   starting from the lowest free
10: end if

```

Note that no robber will be placed on the same starting vertex as the cop (and if $i = 1$, then put R_1 on b_2). There will be at least one unoccupied big vertex after the placement of the robbers. Let the highest such vertex be v . One of v and u is b_m . The strategy of the robbers will be to move to v and u in the first round after the cop has

moved to capture one robber. If there is a robber R_i , where $i > 2$, who starts on a big vertex, then at least two of the robbers R_1, R_2 , and R_i won't be captured on the first round and can move to any big vertex. Hence, they can move to v and u . If only R_1 is on a big vertex, then at least two of R_1, R_2 and R_3 won't be captured on the first round; R_1, R_2 can move to any big vertex, and R_3 can move to b_m . Therefore, two of them will manage to move to v and u . Thus, if the cop starts on a big vertex, the robbers can damage at least s vertices.

If the cop is initially placed on a small vertex u in L_i , then i must be less than $m - 1$. Otherwise, the cop's vertex will be adjacent to only b_m , and since $n - r - 2 > s$, the robbers can be placed only on vertices, not adjacent to the cop's vertex. Then the initial placement of the robbers will follow the placement strategy in Algorithm 2.

There is at least one unoccupied big vertex v . In the first round, the cop can capture only robbers on big vertices above her. Without loss of generality, let the cop capture R_1 in the first round. Then, R_2 can move to u and R_3 can move to v since R_3 can reach all big vertices. This again leads to at least s damaged vertices. Therefore, if G is a threshold graph with at least 3 big vertices, then $\text{dmg}(G; s) \geq s$. Contradiction with the assumption.

Second case: Suppose that $G = T_2 \cup rK_1$, $r \leq s - 1$, $|S_0| \geq 2$, and $\text{dmg}(G; s) = s - 1$. Here, we can again show a strategy for the robbers for any initial placement of the cop. If the cop starts on b_1 or b_2 , place R_1 and R_2 on small vertices from the S_0 layer and all other robbers on the remaining small vertices. After the first round, at least two of R_1, R_2 , and R_3 are not captured and can move to b_1 and b_2 , damaging at least one of them in the next round. If the cop starts on a small vertex, then there are at least s unoccupied small vertices. As any two small vertices are not adjacent, placing the robbers on them will lead to s damaged vertices, which leads again to contradiction.

Both cases achieve contradiction with the assumption. Hence, if G is a graph on $n \geq 2s + 2$ and $\text{dmg}(G; s) = s - 1$, then G could be at most part of the family $\mathcal{T} = \{T_1 \cup rK_1, r \leq s - 1\} \cup \{T_2 \cup tK_1, |S_0| = 1, t \leq s - 1\}$. The graphs from this family are shown in Figure 2.

(\Leftarrow) Suppose that G is isomorphic to one of the graphs in Figure 2. We will now demonstrate a strategy for the cop that ensures the robbers cannot damage s or more vertices.

First, assume $G = T_1 \cup rK_1$, $r \leq s - 1$, $|S_0| \geq s + 2$. Let the vertices be labeled as shown in Figure 2a. Now, let the cop start on b_1 . Then, each robber will either begin on an isolated vertex or on a vertex adjacent to b_1 . Since $r < s$, the cop can always capture one robber in the first round and return to b_1 in the second round, where she will remain for the rest of the game. With this strategy, no robber can leave their vertex without being immediately captured. Thus, the robbers can damage at most $s - 1$ vertices.

Next, assume that G is a threshold graph shown in Figure 2b, where $G = T_2 \cup rK_1$, $r \leq s - 1$, $|S_0| = 1$, $|S_1| \geq s$. The cop's strategy is to begin on the vertex b_2 . In response, all robbers will start on isolated vertices or on vertices adjacent to b_2 . Since $r < s$, the

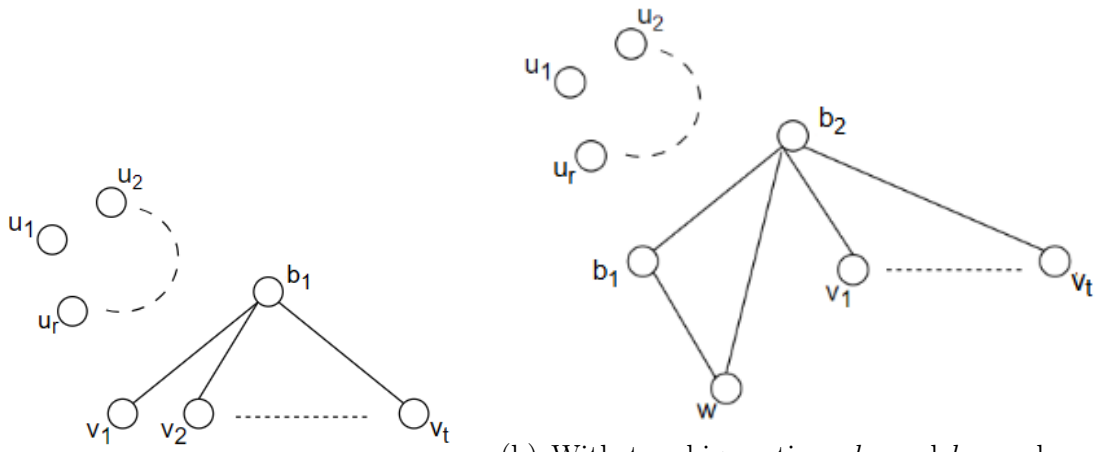

(a) With one big vertex, b_1 , and $r \leq s - 1$. (b) With two big vertices, b_1 and b_2 , and $r \leq s - 1$.

Figure 2: Graphs obtaining $dmg(G; s) = s - 1$ or the members of the family \mathcal{T} .

cop can capture one robber in the first r round. If robber R_i is on b_1 and robber R_j is on w , the cop will consequently capture R_i , return to b_2 , capture R_j , and return to b_2 , where she will remain for the rest of the game. If there is exactly one robber on vertices b_1 and w , the cop will capture him in the first round and then return to v . If all robbers start on the small vertices in S_1 , the cop will capture one of them and then return to b_2 . These three strategies ensure that no more than $s - 1$ vertices are damaged since b_2 is never unoccupied for two consecutive rounds. Therefore, the robbers cannot damage b_2 or leave their initial positions without being captured. Hence, if G belongs to the family \mathcal{G} , then $dmg(G; s) = s - 1$.

Consequently, we have proven that $G \in \mathcal{T}$ if and only if $dmg(G; s) = s - 1$. With this, all graphs G with $n \geq 2s + 2$ vertices that achieve the minimal possible damage number are characterized. \square

It is important to note that for graphs with the lowest possible damage number and $s \geq 3$, our characterization differs from the one presented in [4]. This distinction comes from the fact that after the cop's first move, more than one robber remain in the game. As a result, the robbers have greater freedom of movement and can cause additional damage during their first move. Consequently, we require stricter conditions on the graph. This is why the family \mathcal{T} is a subset of the threshold graphs.

3 Saving k vertices

In [4], the authors state that the cop can always save two vertices of the graph simply by guarding one edge so that its endpoints do not get damaged. Moreover, if $\Delta(G) \geq 3$, the cop can always save three vertices. These observations lead to the question: When can the cop save three vertices against s robbers? In [12], Stojakovic and Wulf examine this

question separately for the family of triangle-free graphs and the family of non-triangle-free graphs. They use Δ_s to denote the smallest integer such that for all non-triangle-free graphs G with $\Delta(G) \geq \Delta_s$, the cop can always save three vertices against s robbers. Similarly, they use Δ'_s to denote the smallest integer, such that for all triangle-free graphs G with $\Delta(G) \geq \Delta'_s$, the cop can always save three vertices against s robbers. They obtain that $\Delta'_s = \binom{s}{2} + 2$ and $2\binom{s}{2} - 3 \leq \Delta_s \leq 2\binom{s}{2} + 1$.

Now, we aim to generalize their results to establish bounds on the smallest $\Delta(G)$ of a graph G such that the cop can always save k vertices against s robbers. To achieve this, we need to introduce the following graph parameters.

Definition 3.1. For $s \geq 1$, let $\Delta_{s,k}$ denote the smallest integer such that for all non-triangle-free graphs G with $\Delta(G) \geq \Delta_{s,k}$, the cop can save k vertices against s robbers.

Moreover, let $\Delta'_{s,k}$ denote the smallest integer such that for all triangle-free graphs G with $\Delta(G) \geq \Delta'_{s,k}$, the cop can save k vertices against s robbers.

In the following two subsections, we prove that for $k \geq 3$, the equality $\Delta'_{s,k} = \binom{s}{2} + k - 1$ holds. Further, we show that for non-triangle-free graphs, for $k \leq 2\binom{s}{2}$, and the positive integer t , such that $2\binom{t-1}{2} < k \leq 2\binom{t}{2}$, we establish the following bounds:

- $2\binom{s}{2} + t - 1 \leq \Delta_{s,k} \leq 2\binom{s}{2} + k - 1$ for t even,
- $2\binom{s}{2} + t - 2 \leq \Delta_{s,k} \leq 2\binom{s}{2} + k - 1$ for t odd.

3.1 Upper bounds

Lemma 3.2. *If the graph G contains an induced star $K_{1,m}$, with $m \geq \binom{s}{2} + k - 1$, then the cop can save k vertices against s robbers.*

Proof. Suppose that G contains an induced star $K_{1,m}$ with v as a central vertex and W as the set of its leaves. The strategy of the cop will be to guard v - to not leave v unattended for two consecutive rounds.

We now adopt the notation from [12]. Let i_1 be the index of the first round in which a robber enters $N(v)$. The cop then moves to capture this robber in round $i_1 + 1$, and returns to v in round $i_1 + 2$. This strategy is repeated for i_2 , the first index with $i_2 \geq i_1 + 2$ where a robber enters $N(v)$ in round i_2 , and similarly for i_3 , and so on.

Next, we show why this strategy ensures that the cop can save v and $k - 1$ vertices from W . Since v is not unattended by the cop for more than one round, it cannot be damaged by a robber. Furthermore, the only rounds in which vertices of W can be damaged are $i_1, i_1 + 1, i_2, i_2 + 1$, and so on. In each round i_j , one robber is captured. Therefore, in rounds $i_j, i_j + 1$, there are at most $s - j$ robbers left. Each uncaught robber can damage at most one vertex in these two rounds (since there are no edges between the vertices of W). Consequently, the robbers damage at most $(s - 1) + (s - 2) + \dots + 1 = \binom{s}{2}$ vertices. Thus, at least $k - 1$ vertices of W remain undamaged. Hence, the cop can save k vertices using this strategy. \square

We will refer to this cop's strategy as $GUARD(v)$ as it will be useful in the next theorems.

Theorem 3.3. *For all $s \geq 2$, we have $\Delta'_{s,k} \leq \binom{s}{2} + k - 1$.*

Proof. Let $m = \binom{s}{2} + k - 1$. Suppose that G is a triangle-free graph and $\Delta(G) \geq m$, then G contains an induced star $K_{1,m}$. Lemma 3.2 states that the cop can save k of the vertices. \square

Theorem 3.4. *For all $s \geq 2$, we have $\Delta_{s,k} \leq 2\binom{s}{2} + k - 1$.*

Proof. Let $s \geq 2$ and suppose that G contains a vertex v of degree at least $2\binom{s}{2} + k - 1$. The cop executes strategy $GUARD(v)$ until no robbers are left.

We claim that the cop can indeed save k vertices. Notice that whenever the cop captures a robber and moves back to v , the remaining r robbers can damage at most $2r$ vertices during these two rounds. Since v is never damaged (there are no two consecutive rounds in which it is unattended), we only need to consider the damage to vertices in $N(v)$. The number of vertices that could get damaged is at most $2(s-1) + 2(s-2) + \dots + 2 \cdot 1 = 2\binom{s}{2}$. Therefore, once all robbers are caught, there are at least $k-1$ undamaged vertices in $N(v)$. Consequently, the cop can protect k vertices in the graph G . \square

Notice that in Theorem 2.3 of [12], they finish the proof of the theorem by observing the moment when only two robbers are left. From [4] we know that if a vertex is of degree at least 3, the cop can save three vertices against two robbers. In the proof of $\Delta_s \leq 2\binom{s}{2} + 1$, Stojakovic and Wulf observe that when only two robbers are left, there are at least three undamaged vertices. Using these two facts, they obtain an upper bound with one less than $2\binom{s}{2} + k - 1$ for $k = 3$. If a similar observation is made about saving k vertices against two robbers, our bound can also be improved.

3.2 Lower bounds

In this section, we use the graphs and notations introduced in Section 2.2. in [12] to give examples with high maximum degrees, where the cop cannot save k vertices. To provide the lower bound, let us introduce the theta graph.

A generalized theta graph $\Theta_{l_1, l_2, \dots, l_m}$ is obtained by connecting two vertices v_1 and v_2 with m internally disjoint paths of lengths l_1, l_2, \dots, l_m . In the case $l_1 = l_2 = \dots = l_m = l$, the theta graph is denoted by $\Theta_{l,m}$ (as denoted in [3]). We will be interested in the graph $\Theta_{7,m}$, shown on Figure 3. If $N(v_1) = \{w_1, \dots, w_m\}$ and $N(v_2) = \{u_1, \dots, u_m\}$, then $\Theta'_{7,m}$ is created from $\Theta_{7,m}$ with the additional assumption that m is even, by adding the edges $\{w_1, w_2\}, \{w_3, w_4\}, \dots, \{w_{m-1}, w_m\}$ and $\{u_1, u_2\}, \{u_3, u_4\}, \dots, \{u_{m-1}, u_m\}$. For convenience, here we will denote $\Theta_{7,m}$ as Θ and $\Theta'_{7,m}$ as Θ' .

Let a *great cycle* be a cycle of length 14 which contains v_1 and v_2 and has no chords. We will say that a robber is *cautious* if he avoids the risk of being caught: he is playing according to a given strategy unless that takes him within the cop's neighborhood, in which case he simply avoids getting caught.

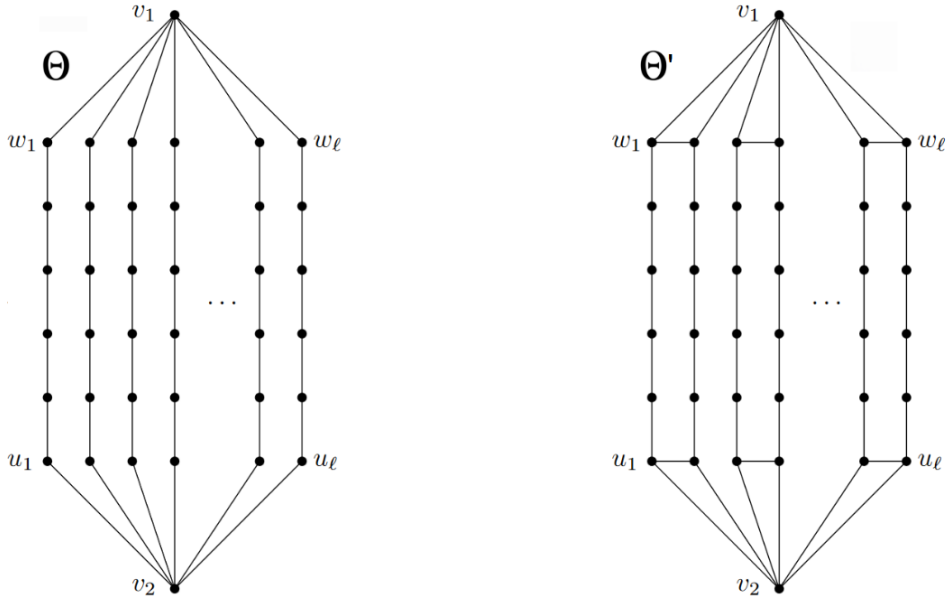

Figure 3: The graphs $\Theta = \Theta_{7,m}$ and $\Theta' = \Theta'_{7,m}$, used for proving the lower bounds on $\Delta'_{s,k}$ and $\Delta_{s,k}$.

In [12], the authors begin their observations by presenting several *auxiliary statements* concerning the strategy of the robbers. These statements serve as foundational lemmas that later help demonstrate that s robbers can always damage $n - 3$ vertices in Θ and Θ' . It is important to note that these auxiliary statements, or lemmas, are general and do not depend on l . These lemmas lead to the following statement.

Lemma 3.5 ([12]). *Let C be a great cycle of Θ' (respectively Θ). If there are at least three robbers, WLOG R_1, R_2, R_3 , positioned at a distance at least two from the cop's position, then they can execute the strategy $CYCLE-ATTACK(C, R_1, R_2, R_3)$ in finitely many moves without a single one of them getting caught. Further, if $CYCLE-ATTACK(C, R_1, R_2, R_3)$ is performed on Θ' (respectively Θ) for every great cycle C , then all of its undamaged vertices are contained in the closed neighborhood of a single vertex.*

The strategy $CYCLE-ATTACK(C, R_1, R_2, R_3)$, presented in [12], is performed by three cautious robbers and ends when all vertices of C are damaged or considerable damage (at least $V(\Theta) \setminus N[x]$, for some $x \in V(\Theta)$; analogically for Θ') to the rest of the graph is done. Formally, it consists of 4 stages.

In Stage 1, the robbers R_1 and R_2 enter the cycle. In Stage 2, the robber R_1 attempts to go clockwise around C , and the robber R_2 attempts to go counterclockwise around C . If during stage 2 both robbers are halted, Stage 3 starts, where the robbers R_1 and R_2 swap their directions of movement on the cycle. If after that they are both halted again, Stage 4 starts, and the robber R_3 comes into play. Suppose that the cop is closer to v_2 than to v_1 . Then, R_3 goes to v_1 and for every i he attempts to go down the path P_i from v_1 to v_2 for as long as possible, while staying cautious and always returns to v_1 between each path. The $CYCLE-ATTACK(C, R_1, R_2, R_3)$ ends, when R_3 has visited every path.

The lemma guarantees that the robbers can execute $\text{CYCLE-ATTACK}(C, R_1, R_2, R_3)$ with a finite number of moves, remain uncaught, and continue using the same strategy for every cycle. This will result in damaging all vertices outside of $N[x]$ for some $x \in V(\Theta)$.

Theorem 3.6. *For all $s \geq 3$ and $k \geq 4$, we have $\Delta'_{s,k} \geq \binom{s}{2} + k - 1$.*

Proof. We will show that s robbers can damage all but at most $k - 1$ vertices, when playing on $\Theta = \Theta_{7,m}$ with $m = \binom{s}{2} + k - 2$.

Arbitrarily choose three robbers R_1, R_2, R_3 to perform the $\text{CYCLE-ATTACK}(C, R_1, R_2, R_3)$ for every great cycle C of Θ . By Lemma 3.5 they can execute this strategy for finitely many moves and damage all vertices outside of $N[x]$ for some $x \in V(\Theta)$ while remaining alive. The other robbers are cautious and remain in the game because they can always keep a distance of at least 2 from the robber.

Suppose that $x = v_2$. Then, there are at most $\binom{s}{2} + k - 1$ undamaged vertices. The remaining robbers repeatedly perform the $\text{ALL-OUT-ATTACK}(r)$ strategy: the remaining r robbers gather at v_1 , each choosing a different path P_i with an undamaged vertex u_i , and simultaneously proceed down their path towards u_i , risking to get caught. Any robber who successfully reaches u_i immediately returns to v_1 . Once all uncaught robbers return to v_1 , the attack is completed. During $\text{ALL-OUT-ATTACK}(r)$, at most one robber is captured, and at least $r - 1$ vertices in $N[v_2]$ are damaged.

As stated in [12], if at any point some robber gets within distance two of the cop while the cop is outside of $N[v_2]$, "an intermission" is activated. During this time, all robbers become cautious and attempt moving towards undamaged vertices in $N(v_2)$, aiming to avoid the cop. If during the "intermission", the cop returns to v_2 , the robbers resume their initial strategy, possibly returning to v_1 first. If an intermission occurs during an $\text{ALL-OUT-ATTACK}(k)$, either an undamaged vertex will be damaged without capturing any robber, or the robbers will successfully return to their main strategy and proceed to the next stage of the attack. Thus, we can assume that intermissions do not affect the overall strategy.

The $\text{ALL-OUT-ATTACK}(r)$ will be completed for $r = s, (s - 1), \dots, 2$, damaging at least $(s - 1) + (s - 2) + \dots + 1 = \binom{s}{2}$. This means that all but $k - 1$ vertices are damaged, completing our proof. The same reasoning applies if $x = v_1$. Furthermore, if $x \neq v_1, v_2$, then $|N[x]| = 3 < k$. Therefore, s robbers have a strategy that ensures fewer than k undamaged vertices, which implies that $\Delta'_{s,k} \geq \binom{s}{2} + k$. \square

Theorem 3.7. *For all $s \geq 3$ and $4 \leq k \leq 2\binom{s}{2}$, we have*

- $\Delta_{s,k} \geq 2\binom{s}{2} + t - 2$ for t odd, and
- $\Delta_{s,k} \geq 2\binom{s}{2} + t - 1$ for t even,

where t is the positive integer, such that $2\binom{t-1}{2} < k \leq 2\binom{t}{2}$.

Proof. We show that $s \geq 3$ robbers have a strategy to leave fewer than k vertices undamaged when playing on $\Theta' = \Theta'_{7,m}$ with $m = 2\binom{s}{2} + t - 3$, where t is odd (the case for t even is analogous).

Choose three robbers R_1, R_2, R_3 , who will perform the CYCLE-ATTACK(C, R_1, R_2, R_3) for every great cycle C of Θ' . By Lemma 3.5, they can execute this strategy for finitely many moves and damage all vertices outside of $N[x]$ for some $x \in V(\Theta')$, while remaining alive. The other robbers are cautious and remain in the game.

Suppose that $x = v_2$. Consequently, the number of undamaged vertices is at most $2\binom{s}{2} + t - 2$. The remaining robbers repeatedly perform the ALL-OUT-ATTACK-2(r): the r remaining robbers gather at v_1 , each robber picks a distinct pair of paths P_{2i-1} and P_{2i} with undamaged u_{2i-1} and u_{2i} , and they simultaneously proceed down their path towards u_{2i-1} , risking to get caught. Each robber that successfully reaches u_{2i-1} , then moves to u_{2i} , and immediately returns to v_1 . The attack ends when all remaining robbers return to v_1 . During ALL-OUT-ATTACK(r), at most one robber is captured, and at least $2(r - 1)$ vertices are damaged.

As stated in [12], and as observed in Theorem 3.6, we can assume no intermissions occur, or that they don't affect the overall strategy.

The ALL-OUT-ATTACK-2(r) will be completed for $r = s, (s - 1), \dots, t$, where t is such that $2\binom{t-1}{2} < k \leq 2\binom{t}{2}$, ensuring $s \geq t$. Upon completing these attacks, the robbers will damage at least $2(s - 1) + 2(s - 2) + \dots + 2(t - 1) = 2\binom{s}{2} - 2\binom{t-1}{2}$ vertices. Thus, all but $2\binom{s}{2} + t - 2 - (2\binom{s}{2} - 2\binom{t-1}{2}) = 2\binom{t-1}{2} + t - 2$ vertices are damaged, and $t - 1$ robbers are still alive.

The final $t - 1$ robbers will gather in v_1 , each choosing a path P_{2i-1} with undamaged vertex u_{2i-1} and simultaneously proceed down towards u_{2i-1} , risking capture (this is possible since $2(t - 1) \leq 2\binom{t-1}{2} + t - 2$). At least $t - 2$ of them will successfully damage their u_{2i-1} , and, for the case t even, one of them will damage the adjacent u_{2i} . Therefore, this will leave at most $2\binom{t-1}{2}$ undamaged vertices, which is strictly less than k according to the definition of t . Hence, the graph Θ' provides the desired bound. The same reasoning applies if $x = v_1$. Furthermore, if $x \neq v_1, v_2$, then $|N[x]| = 3 < k$. Therefore, s robbers have a strategy that ensures fewer than k undamaged vertices, which implies that $\Delta_{s,k} \geq 2\binom{s}{2} + t - 2$ for t odd and $\Delta_{s,k} \geq 2\binom{s}{2} + t - 2$ for t even. \square

4 The s -robber damage number of specific graph families on many vertices

In this section, we determine the s -robber damage number for specific graph families, with a restriction on the order of the graphs. To find an explicit value, we provide a strategy for the cop, which ensures the robbers cannot damage more than a certain number of vertices. This yields the desired upper bound. Similarly, we provide a strategy for the robbers to establish a lower bound.

4.1 Standard graphs

We begin by observing the full bipartite graph $K_{n,m}$. With a restriction on the cardinality of the sets, we find exactly how much $\text{dmg}(K_{n,m}; s)$ is.

Theorem 4.1. *If $n \geq m \geq \left(\left\lfloor \frac{s}{2} \right\rfloor + 1\right)^2$, then $\text{dmg}(K_{n,m}; s) = \binom{s+1}{2}$.*

Proof. Suppose that $K_{n,m}$ is a complete bipartite graph with sets A and B , each having cardinality greater than $\left(\left\lfloor \frac{s}{2} \right\rfloor + 1\right)^2$. First, we show a strategy for the cop that ensures she can protect at least $n - \binom{s+1}{2}$ vertices.

Let the cop start on an arbitrary vertex v . Now, the cop's strategy is as follows: let $i_1 \geq 0$ be the index of the first round, in which a robber enters the set, not containing the cop. The cop then immediately moves to capture this robber in round $i_1 + 1$. The cop repeats this strategy: let i_2 be the first index, where $i_2 \geq i_1 + 1$, such that a robber enters the set not containing the cop, and the cop captures this robber in round $i_2 + 1$, and so on.

The only rounds in which vertices can be damaged are $0, i_1, i_2, \dots$. Moreover, note that in round $i_j + 1$, there are at most $s - j$ robbers left, each capable of damaging at most one vertex in this round. In total, the robbers can damage at most $s + (s - 1) + \dots + 1 = \binom{s+1}{2}$ vertices. Hence, $\text{dmg}(K_{n,m}; s) \leq \binom{s+1}{2}$.

Next, we show that the robbers can indeed damage $\binom{s+1}{2}$ vertices. Place all robbers on distinct vertices in the same set as the cop; without loss of generality, assume this set is A . The strategy of the robbers is as follows: all remaining robbers move to undamaged vertices in A during even rounds, and all remaining robbers move to undamaged vertices in B during odd rounds. Since the cop can capture at most one robber per round (except for the first round) and since $n \geq m \geq \left(\left\lfloor \frac{s}{2} \right\rfloor + 1\right)^2 \geq s + (s - 2) + \dots + (s - 2\lfloor \frac{s}{2} \rfloor)$, each robber can damage a new vertex every round they remain alive. Therefore, the robbers can damage at least $s + (s - 1) + \dots + 1 = \binom{s+1}{2}$ vertices with this strategy. Consequently, $\text{dmg}(K_{n,m}; s) \geq \binom{s+1}{2}$.

Thus, we have proven that both directions of the inequalities hold, implying that $\text{dmg}(K_{n,m}; s) = \binom{s+1}{2}$. \square

Proposition 4.2. *If G is a graph on $n \geq 2\binom{s}{2} + 2$ vertices and it has a universal vertex v , then $\text{dmg}(G; s) \leq 2\binom{s}{2}$.*

Proof. Let the cop start on v , and consequently, the robbers can start on distinct vertices on $G - v$. Since v is adjacent to all vertices, the cop's strategy is to capture a robber during odd rounds and return to v during even rounds. As the cop captures one robber per round, the remaining robbers can each damage at most one additional vertex. Thus, during rounds 1 and 2, at most $2(s - 1)$ vertices are damaged; during rounds 3 and 4, at most $2(s - 2)$ vertices are damaged, and so on. Therefore, the robbers can damage at most $2(s - 1) + 2(s - 2) + \dots + 2 \cdot 1 = 2\binom{s}{2}$ vertices. This implies that $\text{dmg}(G; s) \leq 2\binom{s}{2}$. \square

Now, we give two natural examples of graphs containing a universal vertex, for which the bound from Proposition 4.2 is tight. Let the *wheel graph* W_n of order n be the graph obtained by adding a universal vertex to the cycle C_{n-1} . Further, let the *fan graph* F_n be the graph obtained by adding a universal vertex to the path P_{n-1} .

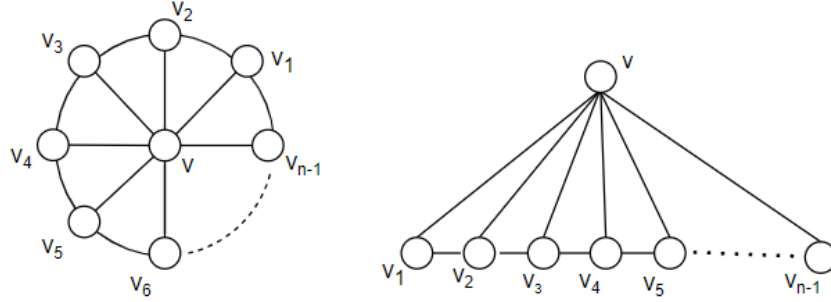

Figure 4: The wheel and fan graph are shown accordingly.

Theorem 4.3. *If $n - 2 \geq 2\binom{s}{2}$, $\text{dmg}(W_n; s) = 2\binom{s}{2}$ and $\text{dmg}(F_n; s) = 2\binom{s}{2}$ for all $s \geq 2$.*

Proof. From Proposition 4.2 the upper bound holds, and we only need to show a strategy for the robbers, so that they can always damage $2\binom{s}{2}$ vertices for $2\binom{s}{2} \leq n - 2$.

Label the vertices of W_n and F_n , as shown in Figure 4. Place the robbers so that R_1 starts on v_1 , and every two consecutive robbers have a distance of $2(s - 1)$ between them. If the cop starts on any of these vertices, shift all robbers one vertex to the right. Each robber's strategy is to move one vertex to the right in each round. Let $\{R_{i_1}, R_{i_2}, \dots, R_{i_s}\}$ be the order in which the robbers are caught. Observe that the cop cannot capture two robbers in consecutive rounds because of the distance between them. The only exception is $s = 2$. In that case, for F_n , the two robbers can start at the two ends of the path, and for W_n , they can start on adjacent vertices, with the uncaptured robber moving away from the cop in the first round.

Robber R_{i_1} will not be caught before the 1^{st} round, R_{i_2} will not be caught before the 3^{rd} , and so on. If a robber is caught in round $2i - 1$, where $i \leq s$, he will have damaged $2i$ vertices. Hence, by round $(2s - 1)$, the robbers can damage at least $2(s - 1) + 2(s - 2) + \dots + 2 \cdot 1 + 2 \cdot 0 = 2\binom{s}{2}$ vertices using this strategy. Therefore, $\text{dmg}(W_n; s) = \text{dmg}(F_n; s) \geq 2\binom{s}{2}$ for $n - 2 \geq 2\binom{s}{2}$. \square

Now, define the *gear graph* G_{2l+1} of order $2l + 1$ as the graph obtained from W_{2l+1} by deleting every other edge incident to the universal vertex. Similarly, define the *accordion graph* F_{2l} of order $2l$ as the graph obtained from P_{2l} by deleting every other edge incident to the universal vertex. These graphs are shown in Figure 5. For them, we are also able to determine an exact value for the s -robber damage number, using a similar strategy.

Theorem 4.4. *If $2l - 2 \geq s(2s - 1)$, $\text{dmg}(G_{2l+1}; s) = s^2$ and $\text{dmg}(F_{2l}; s) = s^2$.*

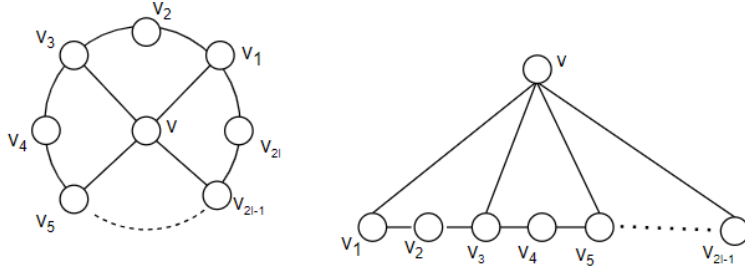

Figure 5: The gear and accordion graph are shown accordingly.

Proof. We will provide the proof for the accordion graph, as the proof for the gear graph is analogous. Label the vertices of A_{2i} , as shown in Figure 5. We will use the notation from the previous theorem.

First, we show the cop's strategy. Let the cop start on v . She aims to capture a robber any time one is in $N(v)$ and to return to v immediately after that. If the cop stays more than one round on v , then during these rounds no robber moves (every vertex in $V(A_{2i}) \setminus N[v]$ is adjacent only to vertices in $N(v)$). W.l.o.g., assume no such rounds exist. Therefore, we can say that the cop moves to capture a robber during even rounds and returns to v during odd rounds. Since all robbers can start on vertices in $V(A_{2i}) \setminus N[v]$, the total number of vertices damaged by the robbers is at most $(2s-1) + (2s-3) + \dots + 3 + 1 = s^2$. Hence, $dmg(A_{2i}; s) \leq s^2$.

Next, we show that the robbers can indeed damage s^2 vertices. Place the robbers so that R_1 starts on v_2 , and every two consecutive robbers have a distance of $2s-1$ between them. Each robber's strategy is to move one vertex to the right in each round. If the cop starts on any of these vertices, shift all robbers one vertex to the left. Again, the cop cannot capture two robbers in consecutive rounds. Robber R_{i_1} will not be caught before the 2^{nd} round, R_{i_2} will not be caught before the 4^{th} , and so on. If a robber is caught in round $2i$, where $i \leq s$, he will have damaged $2i-1$ vertices. Hence, by round $(2s)$, the robbers will have damaged at least $(2s-1) + (2s-3) + \dots + 3 + 1 = s^2$ vertices. Therefore, $dmg(A_{2i}; s) = s^2$. Similarly, we can show that $dmg(G_{2i+1}; s) = s^2$. \square

4.2 The family H_n

A graph family, which has been previously studied in the literature of Cops and Robbers, is the family H_n , illustrated in Figure 6. This graph has been studied in various contexts: in [6], it is presented as an example of a cop-win graph with maximum capture time, and in [5], its damage number is explicitly determined, among others.

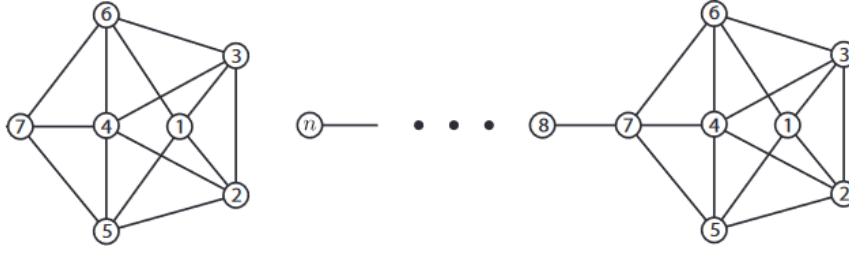

Figure 6: The graph H_n for $n \geq 7$

We want to demonstrate that $s \geq 5$ robbers can cause maximum damage and explore the case $s = 4$. Let us first note two key properties of H_7 : the distance between any two vertices is at most 2, and each vertex v_i has at least one non-adjacent vertex. Since the damage number of H_7 for 3 and 4 robbers is important for the theorems that follow, we present results on these two values in the next Lemma.

Lemma 4.5. *If H_7 is the graph in Figure 6, then $\text{dmg}(H_7; 3) \geq 4$ and $\text{dmg}(H_7; 4) = 5$.*

Proof. Suppose that the robbers R_1, R_2, R_3 (and R_4) play against the cop on H_7 . Table 1 shows a strategy for every initial placement of the cop, which ensures the damage of at least 4 or 5 vertices, respectively. Note that whenever in the third column of Table 1a four vertices are given, the three robbers move to the three unoccupied vertices. One can easily check that these sequences of moves guarantee the desired number of damaged vertices in both cases. □

Table 1 Sequence of movements of the robbers, depending on the cop's starting vertex.

Cop	Round 0	Round 1
v_7	v_1, v_2, v_3	v_5, v_4, v_6
$v_4 \rightarrow v_7$	v_1, v_1, v_7	$v_2, v_3 \rightarrow v_5, v_6$
$v_4 \rightarrow x, x \neq v_7$	v_1, v_1, v_7	v_2, v_3, v_5, v_6
v_1	v_4, v_4, v_7	v_2, v_3, v_5, v_6
v_6	v_5, v_5, v_2	v_7, v_4, v_1, v_3
v_5	v_6, v_6, v_3	v_7, v_4, v_1, v_2
v_2	v_6, v_6, v_7	v_5, v_4, v_1, v_3
v_3	v_5, v_5, v_7	v_6, v_4, v_1, v_2

Cop	Round 0	Round 1
v_4	v_2, v_3, v_5, v_6	v_1, v_4, v_7
v_7	v_2, v_3, v_5, v_6	v_1, v_4, v_7
v_1	v_2, v_3, v_5, v_6	v_1, v_4, v_7
v_6	v_7, v_4, v_1, v_3	v_6, v_5, v_2
v_5	v_7, v_4, v_1, v_2	v_5, v_6, v_3
v_2	v_5, v_4, v_1, v_3	v_2, v_6, v_7
v_3	v_6, v_4, v_1, v_2	v_3, v_5, v_7

(a) Three robbers damage 4 vertices

(b) Four robbers damage 5 vertices

Next, we proceed to show that 4 robbers can damage all but 3 vertices of H_n and 5 robbers can damage all but 2 vertices of H_n .

Theorem 4.6. *If $n \geq 7$ and $s = 4$, then $\text{dmg}(H_n; s) \geq n - 3$.*

Proof. Suppose that robbers R_1, R_2, R_3 and R_4 play the game on H_n for $n \geq 7$. The cop can always save two vertices, so $dmg(G; s) \leq n - 2$. Next, we show a strategy for the robbers, based on the initial placement of the cop, that allows them to damage at least $n - 3$ vertices.

First case: Suppose the cop starts on v_i , where $i \geq 8$. In this case, we say that she begins on the path $v_7 v_8 \dots v_n$. From [4], we know that $dmg(P_n; s) = n - 2$ for $s \geq 2$. Therefore, the robbers' strategy is to place two robbers to damage the path and two robbers to damage the vertices of $H_7 - v_7$, which can always be achieved within three rounds.

If the cop starts on v_i and $i \geq 9$, for $n \geq 9$, place R_1 and R_2 according to the strategy in Theorem 3.3 in [4] to damage the path $v_n - v_7$, and place R_3 and R_4 on v_5 and v_6 . Robbers R_1 and R_2 follow the strategy used in the proof of Theorem 3.3 in [4], while R_3 and R_4 move to v_4 and v_1 and then to v_3 and v_2 . Since the cop needs at least three rounds to reach v_4 , the robbers will damage all the vertices in $H_7 - v_7$ and at least $n - 8$ vertices on the path.

If the cop starts on v_8 and $n \geq 10$, place R_1 on v_{10} and R_2, R_3 , and R_4 on v_4, v_5 , and v_6 . Robber R_1 mirrors the cop's moves until either v_9 or v_7 is damaged, after which he begins damaging consecutively the vertices on the path. Meanwhile, R_2, R_3 , and R_4 move to v_1, v_2 , and v_3 , and all vertices of $H_7 - v_7$ are damaged in the second round. If both v_7 and v_9 remain undamaged afterwards, the robbers attempt to return to v_7 , allowing R_1 to proceed with the next stage of his strategy. Using this approach, the robbers will damage all but two vertices.

The remaining cases are for $n = 8$ and $n = 9$, where the cop starts on v_8 . For $n = 8$, the robbers start on v_6, v_5, v_4 , and v_1 , and then move to v_2 and v_3 , which leads to 6 damaged vertices. For $n = 9$, place the robbers on v_9, v_6, v_5 , and v_4 . If the cop moves to v_7 in the first round, the robbers move to v_1, v_2 , and v_4 . If the cop moves to v_9 , the robbers move to v_7, v_1 , and v_2 , and then to v_3 in the next round. In both cases, they can damage all but two vertices.

Second case: If the cop starts on v_i , $i \leq 7$, the robbers have the following strategy:

Position robber R_1 on the path $v_n - v_7$ at a distance two from the cop (either on v_7, v_8 or v_9). Robber R_1 's objective is to damage all vertices v_i , $i \geq 8$, and robbers R_2, R_3 and R_4 play according to the strategy in Theorem 4.5. Note that R_1 can always execute his strategy since he keeps a distance of at least 2 from the cop in every round, damaging the path vertices consecutively. We can assume that the cop does not leave H_7 , since otherwise, R_2, R_3 and R_4 will damage even more vertices in H_7 . Note that if the cop starts on v_7 and R_1 starts on v_9 , then R_1 can stay in v_9 until the cop moves to $H_7 - v_7$, which will eventually happen. At that point, R_1 will move to v_8 and proceed to damage all remaining vertices on the path consecutively. From Lemma 4.5, we know that $dmg(H_7; 3) \geq 4$. Therefore, when R_1 starts visiting all vertices on the path consecutively, the three other robbers can damage 4 of the vertices in H_7 . This leads us to the conclusion that $dmg(H_n; 4) \geq n - 3$ for $n \geq 7$.

□

This theorem shows that with 4 robbers, we can damage almost the optimal number of vertices. From here, we want to see whether one more robber will secure the damage of $n - 2$ vertices. The next theorem answers this question affirmatively.

Theorem 4.7. *If $n \geq 7$, then $\text{dmg}(H_n; 5) = n - 2$.*

Proof. Suppose that robbers R_1, R_2, R_3, R_4 and R_5 play the game on H_n for $n \geq 7$. The cop can always save two vertices, so $\text{dmg}(G; s) \leq n - 2$. Next, we show a strategy for the robbers that ensures the damage of at least $n - 2$ vertices.

Note that in the previous theorem, we proved that four robbers can damage $n - 2$ vertices when the cop starts on v_i , where $i \geq 8$ and $n \geq 8$. Consequently, this also holds for five robbers, so we only need to consider the cases where the cop starts on v_i , where $i \leq 7$ and $n \geq 7$. Position R_1 on a vertex of the path $v_n - v_7$ at a distance two from the cop, and R_2, R_3, R_4 and R_5 according to the strategy in Theorem 4.5. Robber R_1 's objective is to damage all vertices v_i , $i \geq 8$, which we observed is possible in Theorem 4.6. We can assume that the cop does not leave H_7 , as otherwise, the robbers will be able to damage more vertices in H_7 . From Lemma 4.5, we know that $\text{dmg}(H_7; 4) = 5$. Therefore, while R_1 visits all vertices on the path consecutively, the four other robbers can damage 5 of the vertices in H_7 . This leads us to the conclusion that $\text{dmg}(H_n; 5) = n - 2$ for $n \geq 7$. \square

5 Future work

From the two theorems in Section 4.2, we see that for H_n , if the cop starts on the path, only 4 robbers are needed to achieve the maximum damage. Additionally, if we remove the restrictions on the starting position of the cop, only 5 robbers are required for the maximum damage of H_n . As stated in [4], in cycles and paths, 2 robbers can achieve optimal damage. These observations lead to the following graph parameter.

Definition 5.1. For a given graph G , let $s_{\min}(G)$ denote the minimum integer, such that $s \geq s_{\min}(G)$ robbers always have a strategy to damage $n - 2$ vertices of G . In other words, $\text{dmg}(G; s) = n - 2$, for every $s \geq s_{\min}(G)$ and $\text{dmg}(G; s) < n - 2$ for every $s < s_{\min}(G)$.

In [4], the authors observe that $s_{\min}(P_n) = s_{\min}(C_n) = 2$, and that for $n \geq 5$, these are the only graphs where $s_{\min}(G) = 2$. The following question arises.

Problem. *Can the graphs G with $s_{\min}(G) = 3$ be characterized?*

In Section 3, we discussed that $s_{\min}(H_n) = s_{\min}(H_7) + 1$. This result is intuitive: if the cop starts on H_7 , then one additional robber is sufficient to damage $H_n \setminus H_7$. If the cop starts on the path, two robbers are enough to damage all but two vertices of the path, and $s_{\min}(H_7) - 1$ robbers can damage all vertices in H_7 without interference from the cop. Does this argument extend to other graphs?

Problem. If G is a graph on n vertices, $V(G) = \{v_1, v_2, \dots, v_n\}$, and G' is a graph on $m > n$ vertices, $V(G') = \{v_1, \dots, v_n, \dots, v_m\}$ and $E(G') = E(G) \cup \{v_i v_{i+1} \mid n \leq i \leq m-1\}$, then is it true that $s_{\min}(G') \leq s_{\min}(G) + 1$? For what graphs G does $s_{\min}(G') \leq s_{\min}(G) + 1$ hold?

Furthermore, if G'' is a graph on m vertices, $V(G'') = \{v_1, \dots, v_n, \dots, v_m\}$ and $E(G'') = E(G') \cup \{v_m, v_j\}$, where $j \leq n - 1$, then is it true that $s_{\min}(G'') \leq s_{\min}(G) + 1$? For what graphs G does $s_{\min}(G'') = s_{\min}(G) + 1$ hold?

In [10], Amanda Porter establishes the bound $\text{dmg}(G) \geq \text{rad}(G) - 1$. We can also use the bound $\text{dmg}(G; s) \geq \text{dmg}(G)$ for $s \geq 2$. With this in mind, if we aim to characterize the graphs G such that $\text{dmg}(G; s) = k$, we can infer that $\text{rad}(G) \leq k - 1$.

Problem. For the graphs G with $\text{dmg}(G; s) = k$ for fixed s and k , is there a stronger bound on $\text{rad}(G)$ than $\text{rad}(G) \leq k - 1$?

References

- [1] BONATO, A., GOLOVACH, P., HAHN, G., AND KRATOCHVÍL, J. The capture time of a graph. *Discrete Mathematics* 309, 18 (2009), 5588–5595.
- [2] BONATO, A., AND NOWAKOWSKI, R. *The game of cops and robbers on graphs*. American Mathematical Soc., 2011.
- [3] BUKH, B., AND TAIT, M. Turán numbers of theta graphs. *Combinatorics, Probability and Computing* 29, 4 (2020), 495–507.
- [4] CARLSON, J., HALLORAN, M., AND REINHART, C. The multi-robber damage number of a graph. *arXiv preprint arXiv:2205.06956* (2022).
- [5] COX, D., AND SANAEI, A. The damage number of a graph. *Australas. J Comb.* 75 (2019), 1–16.
- [6] GAVENČIAK, T. Cop-win graphs with maximum capture-time. *Discrete Mathematics* 310, 10-11 (2010), 1557–1563.
- [7] GOLUMBIC, M. C. *Algorithmic graph theory and perfect graphs*, vol. 57. Elsevier, 2004.
- [8] HUGGAN, M. A., MESSINGER, M., AND PORTER, A. The damage number of the cartesian product of graphs. *AUSTRALASIAN JOURNAL OF COMBINATORICS* 88, 3 (2024), 362–384.
- [9] NOWAKOWSKI, R., AND WINKLER, P. Vertex-to-vertex pursuit in a graph. *Discrete Mathematics* 43, 2-3 (1983), 235–239.

- [10] PORTER, A. *Exploring the Damage Number of a Graph*. Undergraduate honours thesis, Mount Allison University, 2022.
- [11] QUILLIOT, A. *Jeux et pointes fixes sur les graphes*. PhD thesis, Ph. D. Dissertation, Université de Paris VI, 1978.
- [12] STOJAKOVIĆ, M., AND WULF, L. On the multi-robber damage number. *arXiv preprint arXiv:2209.10965* (2022).
- [13] THÉRIAULT, B. Reconnaissance des graphes policier-gagnants. *M.Sc. Thesis, Université de Montréal* (2006).
- [14] WEST, D. B., ET AL. *Introduction to graph theory*, vol. 2. Prentice hall Upper Saddle River, 2001.